

INVERTED VEE TRACKER

The range of ConvaTech inverted vee trackers are guaranteed to protect and increase the longevity of the conveyor belt by ensuring your belt tracks true.

Our tracker design focuses on improving conveyor performance. This is achieved by reducing maintenance downtime, increasing productivity attributed to belt tracking issues and minimising spillage around the head transition and loading areas.

Balancing cost effectiveness with long life functionality makes our tunnel trackers the ideal choice for your application.

Application

Suitable for single, reversing or short centred conveyors.

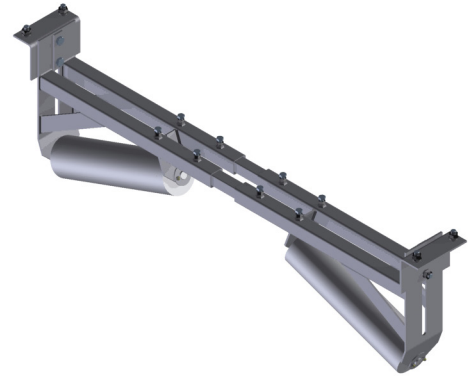

-  Proven Performance
-  Quality Product
-  Flexibility in Design
-  On-time Delivery
-  Australian Owned

FEATURES	BENEFITS
Manufactured from high grade stainless steel	= Increases longevity in structural components
Designed to allow modular assembly and installation	= Allows easier access into tight fitting areas = Reduces manual handling hazards
Designed with minimal moving parts	= Low maintenance required
Designed with telescopic cross beams	= Enables use on any conveyor, at any point
No servo rollers required	= Eliminates risk of belt damage caused by failed servo rollers

Item Code	Description	Unit	Weight (kg)
50-15-001	TS Belt Tracker Inverted Vee 0450 to 0650	Each	18.5
50-15-002	TS Belt Tracker Inverted Vee 0750 to 1200	Each	29
50-15-003	TS Belt Tracker Inverted Vee 1350 to 1800	Each	51

New South Wales

ABN 19 002 924 307

PO Box 126, HRMC NSW 2310
3-7 Ironbark Close, Warabrook NSW 2304

P: 02 4935 0200
E: sales@convatech.com.au

Queensland

ABN 50 119 833 831

PO Box 8, Mackay QLD 4740
25-29 Interlink Court, Mackay QLD 4740

P: 07 4953 9100
E: salesqld@convatech.com.au

Western Australia

ABN 19 002 924 307

Unit 1/61 Mulgool Road
Malaga WA 6090

P: 08 9203 1111
E: sales@convatech.com.au

In partnership with

TSGlobal®

Leaders in Conveyor Products



www.convatech.com.au